

Power spectra and necessary bandwidth for simultaneous FDM and PSK signals

Adel A. ALI and Mohammed A. ALHAIDER

College of Engineering, King Saud University, Riyadh, Saudi Arabia

This paper studies in detail the power spectra and necessary bandwidth for transmission of simultaneous FDM telephone channels and PSK data subcarrier. First, the spectra of the individual signals are derived in a simple form which avoids numerical convolutions. We assume that the modulated PSK carrier is a Gaussian process, and that the emphasis network has ideal characteristics. The FM power spectrum of simultaneous FDM and PSK is then obtained as the convolution of the individual spectra. The derived formulas are used to compute the out-of-band power as a function of bandwidth for a wide range of design parameters. Together with the analytical formulas, design curves are provided in which the out of band

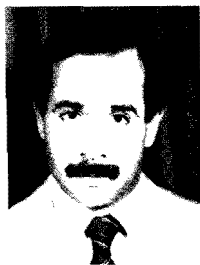

Adel A. Ali, born in Alexandria, Egypt, had B.Sc. in Electrical Engineering from Alexandria University in 1967. He obtained M.Sc. and Ph.D. from the University of Manitoba, Canada in 1973 and 1976, respectively, both in Electrical Engineering. From 1976 to 1978 he was a transmission and special services engineer with Manitoba Telephone System, Winnipeg, Canada. Since 1976 Dr. Ali has been with the Electrical Engineering Department, King Saud University where he is now

an Associate Professor. He also served as a consultant to the Ministry of PTT, Saudi Arabia. Dr. Ali's research interests include communication theory, microwave propagation and coding.



Mohammed A. Alhaider received the B.Sc. degree from King Saud University, Riyadh, Saudi Arabia in 1968 and the M.Sc. and Ph.D. degrees from Carnegie-Mellon University, Pittsburgh, PA, USA in 1972 and 1977, respectively, all in Electrical Engineering. Since 1977 he has been with the College of Engineering, King Saud University, where he is currently an associate Professor and Dean. His areas of interest include optical and microwave communications and acoustooptic interactions in thin films.

North-Holland

Space Communication and Broadcasting 3 (1985) 207-219

power is plotted versus bandwidth for different PSK and FDM parameters. The results are compared to Carson's rule bandwidth and a simple modification of Carson's rule is suggested. The modified formula can be accurately used to estimate bandwidth of high deviation and low deviation signals transmitted over the same RF channel.

The obtained results are applicable to terrestrial microwave, satellite, and cable systems, transmitting analog telephone channels and/or wideband data signals.

Keywords: Satellite, transmission, bandwidth, modulation, spectrum, telephony, data

1. Introduction

The transmission of digital information, along with analog signals in a hybrid mode, has received a considerable attention. Data Above Voice (DAV) and Data Under Voice (DUV), [1]-[3], are two examples of hybrid systems used today in many places. DAV uses the spectrum above the frequency division multiplexed (FDM) voice channels, of microwave or satellite channels, to transmit a digital stream of 1.544 Mb/s (T1) or 2.048 Mb/s (CEPT). While detailed analysis of the DAV system can be found in [4]-[7], spectral analysis and necessary bandwidth were overlooked. As with most FM systems, Carson's rule is used for bandwidth determination. However, as the radio spectrum gets more and more congested, some of its limitations are beginning to appear [8]. Carson's rule has been the subject of study by many authors [9]-[12], who have suggested more elaborate methods of calculating required FM bandwidth; however, only FDM was considered.

In this paper we present detailed FM spectral analyses of the hybrid baseband comprised of FDM and DAV signals. To start, the power spectral density (PSD) of a sinusoidal carrier frequency modulated by the PSK subcarrier is derived. We assume that the modulating signal is a stationary Gaussian process. The digital signal modulating the subcarrier is clearly a non-Gaussian process

(since it has a finite set of values). However, it is shown in [13] that the Gaussian approximation remains plausible for low deviation FM, a condition well satisfied by the PSK signal.

The PSD of a sinusoidal carrier frequency modulated by the FDM signal is then derived in a closed form, utilizing the Middleton expansion [14], and assuming idealized pre-emphasis. The idealized pre-emphasis will result in a flat phase modulating signal, for which the spectrum is different from the actual spectrum, of the CCIR pre-emphasised signal only in the carrier vicinity [15]. Finally, the total spectrum is obtained by convolving the individual spectra of the two independent modulations [15].

The FM spectra are derived in Section 2 and utilized to determine the necessary bandwidth in Section 3. The necessary bandwidth is defined by the regulatory bodies as the frequency band containing a certain percentage of the total RF power, or, the bandwidth out of which the total power is less than a certain percentage, say, one percent. For 600, 960 and 1800 FDM voice channels, the out-of-band power is plotted versus bandwidth for different data subcarrier frequencies and powers. Finally bandwidth computations using the curves are compared to those obtained by applying Carson's rule. The principal conclusion is presented as a modification of Carson's rule that seems more meaningful for the case of a hybrid baseband. For FDM only, our results agree with Carson's rule and with previously published results [9].

2. FM spectra

Consider a sinusoidal carrier, phase modulated by a Gaussian random signal $\phi(t)$ as

$$x(t) = \cos(\omega_c t + \phi(t)). \quad (1)$$

The correlation function of $x(t)$ is given by [17]

$$R_x(\tau) = R_r(\tau)(\cos \omega_0 \tau)/2$$

where

$$R_r(\tau) = \exp[-R_\phi(0) + R_\phi(\tau)] \quad (2)$$

where $R_\phi(\tau)$ is the autocorrelation of the phase modulating signal and $R_\phi(0)$ is the mean square phase modulation. The power spectrum $W_x(f)$ of

$x(t)$ is the Fourier transform of $R_x(\tau)$, hence,

$$W_x(f) = \int_{-\infty}^{\infty} \exp[-R_\phi(0) + R_\phi(\tau)] e^{-j2\pi f\tau} d\tau. \quad (3)$$

Let $R_\phi(0) = p$, eq. (2) can be expanded as

$$R_x(\tau) = e^{-p} \left\{ 1 + \frac{R_\phi(\tau)}{1!} + \frac{R_\phi^2(\tau)}{2!} + \frac{R_\phi^3(\tau)}{3!} + \dots \right\}. \quad (4)$$

Equation (4) may now be transformed term by term. Since $R_\phi(\tau)$ is the autocorrelation of the baseband, its transform is $P_\phi(f)$, the power spectrum of $\phi(t)$, and $W_x(f)$ is now written in the form

$$W_x(f) = e^{-p} \left\{ \delta(f) + P_\phi(f) + \frac{P_\phi(f) \overset{*}{*} P_\phi(f)}{2!} + \frac{P_\phi(f) \overset{*}{*} P_\phi(f)}{3!} + \dots \right\}. \quad (5)$$

where $\delta(f)$ is the delta function and $P_\phi(f) \overset{*}{*} P_\phi(f)$ denotes $P_\phi(f)$ convolved with itself $(n-1)$ times. The expansion in (5) is expressed in terms of the normalized baseband spectrum $w_\phi(f)$.

Let $p w_\phi(f) = P_\phi(f)$. The total rms deviation is defined as

$$P = \int_{-\infty}^{\infty} P_\phi(f) df \quad (6)$$

Then

$$\int_{-\infty}^{\infty} w_\phi(f) df = 1 \quad (7)$$

and the FM spectrum is finally given by

$$W_x(f) = e^{-p} \left\{ \delta(f) + p w_\phi(f) + \frac{p^2}{2!} w_\phi(f) \overset{*}{*} w_\phi(f) + \frac{p^3}{3!} w_\phi(f) \overset{*}{*} w_\phi(f) + \dots \right\}. \quad (8)$$

This expansion has been studied by many researchers, [15] for example. It has been pointed out that the expansion fails if the modulating spectrum is not zero at the origin ($P_\phi(0) \neq 0$). If the modulating spectrum does not vanish at the origin, the rms phase deviation p is infinite and the expansion has to be written in terms of the

frequency parameters instead of phase. Thus eq. (2) is rewritten as

$$R_{\phi}(f) = \exp(1 - K(\tau)) \quad (9)$$

where

$$K(\tau) = -R_{\phi}(0) + R_{\phi}(\tau),$$

and, noting that $P_{fd}(f)$, the spectral density of the instantaneous frequency deviation, is related to $P_{\phi}(f)$, the spectrum of the instantaneous phase deviation, by the relation

$$P_{fd}(f) = f^2 P_{\phi}(f) \quad (10)$$

we can write $K(\tau)$ as

$$K(\tau) = 2 \int_{-\infty}^{\infty} P_{fd}(f) \left(\frac{\sin \pi f \tau}{f} \right)^2 df. \quad (11)$$

Evaluating FM spectra when the modulating signal is non-zero at $f=0$ requires evaluating the integral in (11) and finding the Fourier transform of eq. (9). In the remainder of this section we determine the FM spectrum of the FDM signal, based on expansion (8). For the PSK signal $p(f) \neq 0$ at $f=0$. Hence the FM spectrum due to the PSK signal may be obtained following the analysis of eqs. (9)–(11).

2.1. Contribution of the PSK signal to the FM spectrum

Because of its advantages in both power and bandwidth efficiency, PSK digital modulation [16] has been used extensively. We consider the cases of 2 or 4 level phase modulation as the method of subcarrier modulation. The spectral density for a 2

or 4-level PSK modulated carrier $P_{psk}(f)$ is expressed as [5]

$$P_{psk}(f) = \frac{D_d^2}{2B} \left[\left(\text{sinc} \left(\frac{f-f_d}{B} \right) \right)^2 + \left(\text{sinc} \left(\frac{f+f_d}{B} \right) \right)^2 \right] \quad (12)$$

where D_d^2 is the subcarrier power at the FM modulator input, B is the symbol rate of the digital signal ($B = \frac{1}{2} B_R$ for 4-level and $B = B_R$ for 2-level modulation, and B_R is the bit rate), f_d is the subcarrier frequency and $\text{sinc } x = (\sin \pi x) / \pi x$. The PSK sub-carrier may be inserted after the pre-emphasis and extracted before the de-emphasis network. However, if the FDM signal and data subcarrier are combined before the pre-emphasis, the emphasis network loss at the subcarrier frequency f_d must be accounted for, when setting the subcarrier power D_d^2 . The system block diagram is shown in Fig. 1.

To find the FM spectrum of a sinusoidal carrier frequency modulated by the PSK signal having the spectrum $P_{psk}(f)$ of (12), we follow eqs. (9) and (10) to get

$$R_{psk}(\tau) = \exp \left[-2 \int_{-\infty}^{\infty} P_{psk}(f) \frac{\sin^2 \pi f \tau}{f^2} df \right]. \quad (13)$$

Equation (13) is exact for Gaussian modulation. However, for low modulation indices (total frequency deviation/bandwidth of frequency deviation) the use of (13) remains plausible for non-Gaussian modulation [17]. For typical values of modulation parameters, it can be shown that the data modulation index $q \sim 0.01$, hence, $q \ll 1$. Now substituting for $P_{fd}(f)$ from (12) into (13)

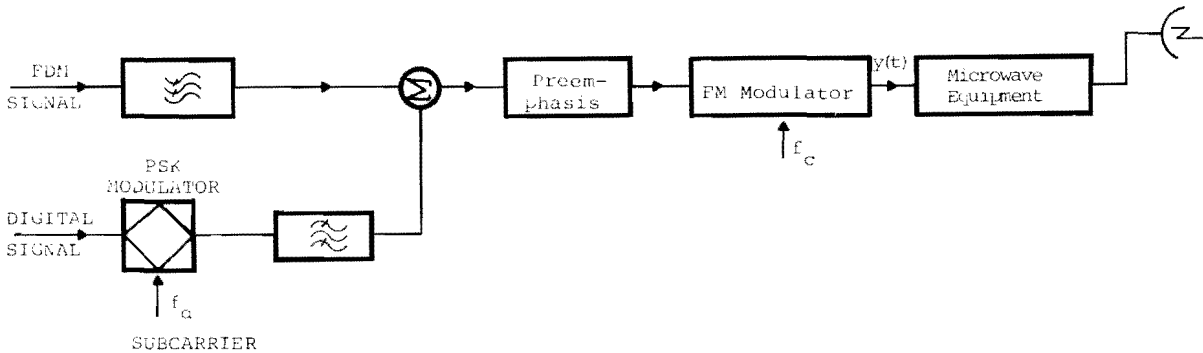

Fig. 1. Transmission system block diagram.

and integrating we get

$$K(\tau) = \begin{cases} q \left[1 - (1 - B|\tau|) \cos^2 \pi f_d \tau - \frac{\sin 2\pi f_d |\tau|}{2\pi f_d / B} \right], & 0 \leq B|\tau| \leq 1, \\ q[1 - C + \alpha B|\tau|], & B|\tau| \geq 1 \end{cases}$$

where

$$q = \frac{2D_d^2}{f_d^2}, \quad \alpha = \sin^2 \frac{\pi f_d}{B}, \quad (14)$$

$$C = \sin^2 \frac{\pi f_d}{B} \operatorname{sinc} \frac{2f_d}{B}.$$

The power spectral density $W_{\text{psk}}(f)$ of the data subcarrier about the FM carrier f_c is now found as the Fourier transform of $R_{\text{psk}}(\tau)$:

$$W_{\text{psk}}(f) = 2 \int_0^{1/B} R_{\text{psk}}(\tau) \cos 2\pi f \tau \, d\tau + \int_{1/B}^{\infty} R_{\text{psk}}(\tau) \cos 2\pi f \tau \, d\tau \quad (15)$$

$$= W_1(f) + W_2(f). \quad (16)$$

The integral from $1/B$ to ∞ can be readily evaluated as

$$W_2(f) = \frac{2A}{B} e^{-q} \times \frac{\alpha \cos 2\pi f/B - 2\pi f/B \sin 2\pi f/B}{(2\pi f/B)^2 + \alpha^2}, \quad (17)$$

where

$$A = e^q \operatorname{sinc} 2f_d/B,$$

and the value of $W_1(f)$ is found by first expanding the exponential function in a power series of τ and integrating term by term to get

$$W_1(f) = e^{-q} \sum_{m=0}^{\infty} \frac{q^m}{m!} S_m(f), \quad (18)$$

where

$$S_m(f) = \frac{1}{2^{2m}} \left\{ \frac{(2m)!}{(m!)^2} G_m(f) + \sum_{r=0}^{m-1} (r^{2m}) [G_m(f - (m-r)f_d) + G_m(f + (m-r)f_d)] \right\} \quad (19)$$

where $G_m(f)$ is given by the recurrence relation

$$G_m(f) = \frac{2m}{B(2\pi f/B)^2} \left[1 - \frac{1}{2}(m-1)BG_{m-2} \right], \quad m \geq 2, \quad (20a)$$

$$G_0(f) = \frac{2}{B} \operatorname{sinc} 2f/B, \quad (20b)$$

$$G_1(f) = \frac{1}{B} \operatorname{sinc}^2 f/B. \quad (20c)$$

The total power spectral density of the PSK signal is now written as

$$W_{\text{psk}}(f) = e^{-q} \left\{ \sum_{m=0}^{\infty} \frac{q^m}{m!} S_m(f) + \frac{2A}{B} \left(\frac{\alpha \cos 2\pi f/B - 2\pi f/B \sin 2\pi f/B}{(2\pi f/B)^2 + \alpha^2} \right) \right\}. \quad (21)$$

The above expression for $W_{\text{psk}}(f)$ is similar to the Middleton expansion (eq. (8)), since both are made up of infinite series of normalized terms ($\int_{-\infty}^{\infty} S_m(f) df = 1$) with weighting coefficients given by terms of the Poisson distribution $e^{-q} q^m / m!$. We note that the total power in $W_2(f)$ is zero and since $S_m(f)$ is a set of normalized functions, the Poisson coefficient add to one, giving a total power of unity in the PSK-FM spectrum, as one expects.

To answer the question of how many terms should be considered in (21), we first recall that the Poisson distribution has a maximum when $m = q$. Hence, for small q only the first terms need be considered; for large q , only those terms for which $q \sim m$ need be considered. For small modulation index, $q \ll 1$, a simplified expression for the PSK-FM spectrum $W_{\text{psk}}(f)$ can be written with q^2 and higher power neglected to get

$$W_{\text{psk}}(f) = e^{-q} \left\{ S_0(f) + qS_1(f) + \frac{2A}{B} \frac{\alpha \cos 2\pi f/B - 2\pi f/B \sin 2\pi f/B}{\alpha^2 + (2\pi f/B)^2} \right\}. \quad (22)$$

For typical DAV systems, the rms frequency deviation $D_d \sim 0.4$ MHz; $f_d \sim 6$ MHz, yielding $q \sim 0.01$. For frequencies around the RF carrier, higher than the signaling rate $2\pi f/B \gg \alpha$ and

$A \sim 1$, the PSK-FM spectrum simplifies to

$$W_{\text{psk}}(f) \sim \frac{1}{4B} \left\{ 2 \operatorname{sinc}^2 \frac{f}{B} + \operatorname{sinc}^2 \left(\frac{f-f_d}{B} \right) + \operatorname{sinc}^2 \left(\frac{f+f_d}{B} \right) \right\}. \quad (23)$$

To summarize our results, three expressions for the PSK-FM spectrum have been derived: an exact formula given by (21), an approximation for low deviation given by eq. (22) and the spectrum away from the carrier given by eq. (23). We note that the power neglected in eq. (22) is below -50 dB down from the total power, for $q \sim 0.003$.

2.2. Contribution of the FDM signal to the FM spectrum

Spectral characteristics of FDM-FM signals have received continuing attention for over two decades. In most of the published work [18]–[25], the FDM signal is modeled as a band-limited Gaussian noise, with the proper emphasis applied before modulation. For low deviation modulation, the spectrum is given by the first few terms of Middleton expansion which requires the evaluation of repeated convolutions of the pre-emphasized baseband [12]. For large modulation indices (the quasi-stationary case), the probability density function of the baseband signal is a reasonable approximation to the power spectrum in the carrier vicinity; however, its accuracy is questionable in the tails [23].

In this section we present a closed form expression for the FM spectrum for FDM signal with idealized emphasis. Although the recommended CCIR emphasis characteristics is not ideal, the difference in the spectral shape is only appreciable in the vicinity of the carrier. Unlike existing methods, no numerical evaluation of the repeated convolutions of the pre-emphasized signal are required. The present method is not restricted to low deviation modulation. The FDM spectrum can be modeled by a band-limited Gaussian signal as

$$P(f) = \begin{cases} K^2, & f_1 \leq |f| \leq f_2, \\ 0, & \text{otherwise.} \end{cases} \quad (24)$$

If we assume that the pre-emphasis network has

idealized characteristics, then the phase spectrum $P_\phi(f)$ of the modulating signal can be written as [15]

$$P_\phi(f) = \begin{cases} \frac{p}{2(f_2 - f_1)}, & f_1 \leq |f| \leq f_2, \\ 0, & \text{otherwise} \end{cases} \quad (25)$$

where the mean square phase deviation p is related to the mean square frequency deviation ΔF by the relation

$$p = \frac{\Delta F}{f_2^2 + f_1 f_2 + f_1^2} (\text{rad})^2. \quad (26)$$

The PSD about a sinusoidal carrier frequency modulated by the FDM signal can now be written using the Middleton expansion of eq. (8) to get

$$W_{\text{FDM}}(f) = e^{-p} \left\{ d(f) + p w_{\text{fdm}}(f) + \frac{p^2}{2!} w_{\text{fdm}}(f) * w_{\text{fdm}}(f) + \dots \right\} \quad (27)$$

where

$$w_{\text{fdm}}(f) = \frac{1}{p} P_\phi(f) = \begin{cases} \frac{1}{2(f_2 - f_1)}, & f_1 \leq |f| \leq f_2, \\ 0, & \text{otherwise.} \end{cases} \quad (28)$$

Although an exact, closed form expression for the repeated convolutions in eq. 27 can be derived, a simplified expression can be obtained if we let the lower frequency f_1 extend to zero. Define

$$w_n(f) = w_{\text{fdm}}(f) * w_{\text{fdm}}(f). \quad (29)$$

A closed form expression of $w_n(f)$ can be derived in the form

$$w_n(f) = \begin{cases} \frac{n}{2^n f_m} \sum_{0 \leq r < \lfloor y+n \rfloor / 2} \frac{(-1)^r (y+n-2r)^{n-1}}{r!(n-r)!}, & 0 < y < n, \\ 0, & y \geq n \end{cases} \quad (30)$$

where $f_m = f_2$ is the highest modulating frequency

and $y = f/f_m$. Substituting from (30) into (27) we get

$$W_{\text{FDM}}(f) = e^{-p} \sum_{n=0}^{\infty} \frac{(p)^n}{n!} w_n(f) \quad (31a)$$

$$= e^{-p} \sum_{n=0}^{\infty} \frac{(p)^n}{n!} \frac{n}{2^n f_m} \times \sum_r \frac{(-1)^r (y+n-2r)^{n-1}}{r!(n-r)!}. \quad (31b)$$

The summation over r sums up different sections of the convolved signal, while the summation with respect to n is carried over the sidebands of the modulated signal. The total power in the n th order sideband is given by $e^{-p}(p)^n/n!$. Hence for a given modulation index p , the number of terms can be found for a prescribed accuracy. For 1800 channels having a mean square phase deviation of 0.05 rad^2 , the distortion resulting from deleting third and higher order sidebands is -47 dB ; adding the third order lowers the distortion down to -65 dB .

2.3. The total spectrum

The power spectral density about a carrier which is frequency modulated by the sum of two statistically independent phase modulations is the convolution of the spectra about two individual carriers modulated by each phase disturbance separately [15]. Since the FDM and PSK are statistically independent, we can apply the above property to find the total spectrum $W_i(f)$ of the simultaneous FDM and PSK data above voice

$$W_i(f) = W_{\text{FDM}}(f) * W_{\text{PSK}}(f). \quad (32)$$

Substituting for $W_{\text{FDM}}(f)$ from eq. (31) into eq. (32) we get

$$W_i(f) = W_{\text{PSK}}(f) * \sum_{n=0}^{\infty} e^{-p} \cdot \frac{(p)^n}{n!} w_n(f) \quad (33)$$

$$= W_{\text{PSK}}(f) * \left[e^{-p} \delta(f) + e^{-p} \sum_{n=1}^{\infty} \frac{p^n}{n!} w_n(f) \right]$$

$$= e^{-p} W_{\text{PSK}}(f) + W_{\text{PSK}}(f) * W'_{\text{FDM}}(f) \quad (34)$$

where

$$W'_{\text{FDM}}(f) = W_{\text{FDM}}(f) - e^{-p} \delta(f).$$

$W'_{\text{FDM}}(f)$ is the FDM power spectrum excluding the carrier component $\delta(f)$. Equation (33) can be written as

$$W_i(f) = e^{-p} W_{\text{PSK}}(f) + \left(e^{-(p+q)} \sum_{m=0}^{\infty} \sum_{n=1}^{\infty} \frac{q^m}{m!} \frac{p^n}{n!} S_m(f) * w_n(f) \right) + \left(e^{(p+q)} \sum_{n=1}^{\infty} \frac{2A}{B} \frac{p^n}{n!} \times \frac{\alpha \cos 2\pi f/B - 2\pi f/B \sin 2\pi f/B}{(2\pi f/B)^2 + \alpha^2} * w_n(f) \right). \quad (35)$$

The convolution in eq. (35) can be evaluated analytically by first obtaining the Fourier transform of both $w_n(f)$ and $S_m(f)$ and then the inverse transform of their product. However, it is sufficient in the low data modulation index to have

$$W_i(f) \cong e^{-p} W_{\text{PSK}}(f) + e^{-q} W'_{\text{FDM}}(f) + e^{-q} \sum_{m=1}^{\infty} \frac{q^m}{2^{2m} m!} \left\{ \sum_{r=0}^{m-1} \binom{2m}{r} \times \left[W'_{\text{FDM}}(f - (m-r)f_d) + W'_{\text{FDM}}(f + (m-r)f_d) + \binom{2m}{m} W'_{\text{FDM}}(f) \right] \right\}. \quad (36)$$

The total spectrum $W_i(f)$ of (36) is an infinite series expansion, as expected for most FM spectra. The main part of the spectrum is formed by the two individual spectra, where the weights e^{-p} , e^{-q} indicate that the total power is constant. Hence, as p increases, the effect of the FDM signal dominates the spectrum, and similarly for q . The remaining part of $W_i(f)$ represents the higher order sidebands due to the interaction between the PSK and FDM spectra and shows up in the FDM spectrum

at the harmonics of the data subcarrier frequency f_d . Two limiting cases are derived from eq. (36) as follows:

$$\begin{aligned} \lim_{q \rightarrow 0} W_1(f) &= W_{\text{FDM}}(f), \\ \lim_{p \rightarrow 0} W_1(f) &= W_{\text{PSK}}(f). \end{aligned} \quad (37)$$

3. Necessary bandwidth

Necessary bandwidth is defined by the ITU (International Telecommunication Union) as: "...bandwidth sufficient to insure the transmission of information at the rate and with the quality required for the system employed..." [8]. For radio systems this bandwidth is often specified as the frequency band containing a certain fraction of the total RF power. Regulatory bodies specify 99 percent, 99.5 percent, etc., as the required in-band power, permitting a maximum of 1 or 0.5 percent of the power to fall outside the 'allocated' or 'authorized' band. The concern is that the out-of-band power will fall into neighbouring channels causing adjacent channel interference. Interference cases can be resolved by comparing the power spectra of the 'wanted' and 'unwanted' or 'victim' and 'interfering' channels. The expressions presented in Section 2 are intended for such applications. On the other hand, it was found that out-of-band powers in the range of 30–60 dB below the unmodulated carrier may cause interference into adjacent channels. This figure was based on the assumption that cross polarization and nearly equal power are used on the co-channel.

Our aim now is to define the necessary bandwidth for transmitting the hybrid FDM and PSK baseband based on the calculation of out-of-band power. Hence, a set of curves will be drawn for the out-of-band power versus bandwidth. Bandwidth calculation from these curves and Carson's rule will be compared.

3.1. Out-of-band power for PSK-FM spectrum

The total power $\bar{W}_{\text{PSK}}(F)$ contained in a band extending from $-F$ to F around the carrier can be

found as

$$\bar{W}_{\text{PSK}}(F) = \int_{-F}^F W_{\text{PSK}}(f) df \quad (38)$$

$$\begin{aligned} &= \int_{-F}^F \bar{W}_1(f) df + \int_{-F}^F \bar{W}_2(F) df \\ &= \bar{W}_1(F) + \bar{W}_2(F) \end{aligned} \quad (39)$$

and similarly,

$$W_1(F) = e^{-q} \sum_{m=0}^{\infty} \bar{S}_m(F).$$

$\bar{S}_m(F)$ can be found from (19) with $\bar{S}(F)$ and $\bar{G}(F)$ replacing $S(f)$ and $G(f)$ respectively. Straightforward, but lengthy, manipulations can be used to show that $\bar{G}(F)$ is given by

$$\begin{aligned} \bar{G}_{2m}(F) &= \bar{G}_{2m-1}(F) + \frac{(-1)^{m-1}(2m-1)!}{x^{2m}} \\ &\quad \times \left\{ \sin x - \sum_{r=0}^{m-1} \frac{(-1)^r x^{2r+1}}{(2r+1)!} \right\}, \\ \bar{G}_{2m+1}(F) &= \bar{G}_{2m}(F) + \frac{(-1)^m(2m)!}{x^{2m+1}} \\ &\quad \times \left\{ \cos x - \sum_{r=0}^m \frac{(-1)^r x^{2r}}{(2r)!} \right\}. \end{aligned} \quad (40)$$

To determine the contribution of $W_2(f)$ to the transmitted power we first expand the denominator of $W_2(f)$ using the binomial theorem and integrating to get

$$\begin{aligned} \bar{W}_2(F) &= \int_{-F}^F W_2(f) df \\ &= \Delta_0 \left(\frac{\pi}{2} - \text{Si}(x) \right) \\ &\quad + \sum_{n=1}^{\infty} (-1)^n \left[\frac{(2n-2)! \cos x}{x^{2n-1}} \Delta_{2n-1} \right. \\ &\quad \left. + \frac{(2n-1)! \sin x}{x^{2n}} \Delta_{2n-1} \right] \end{aligned} \quad (41)$$

where

$$\Delta_n = \sum_{r=n}^{\infty} \frac{\alpha^r}{r!}, \quad \Delta_0 = e^\alpha, \quad \Delta_1 = e^\alpha - 1, \dots$$

and $\text{Si}(x)$ is the sine integral, i.e.

$$\text{Si}(x) = \int_0^x \frac{\sin t}{t} dt.$$

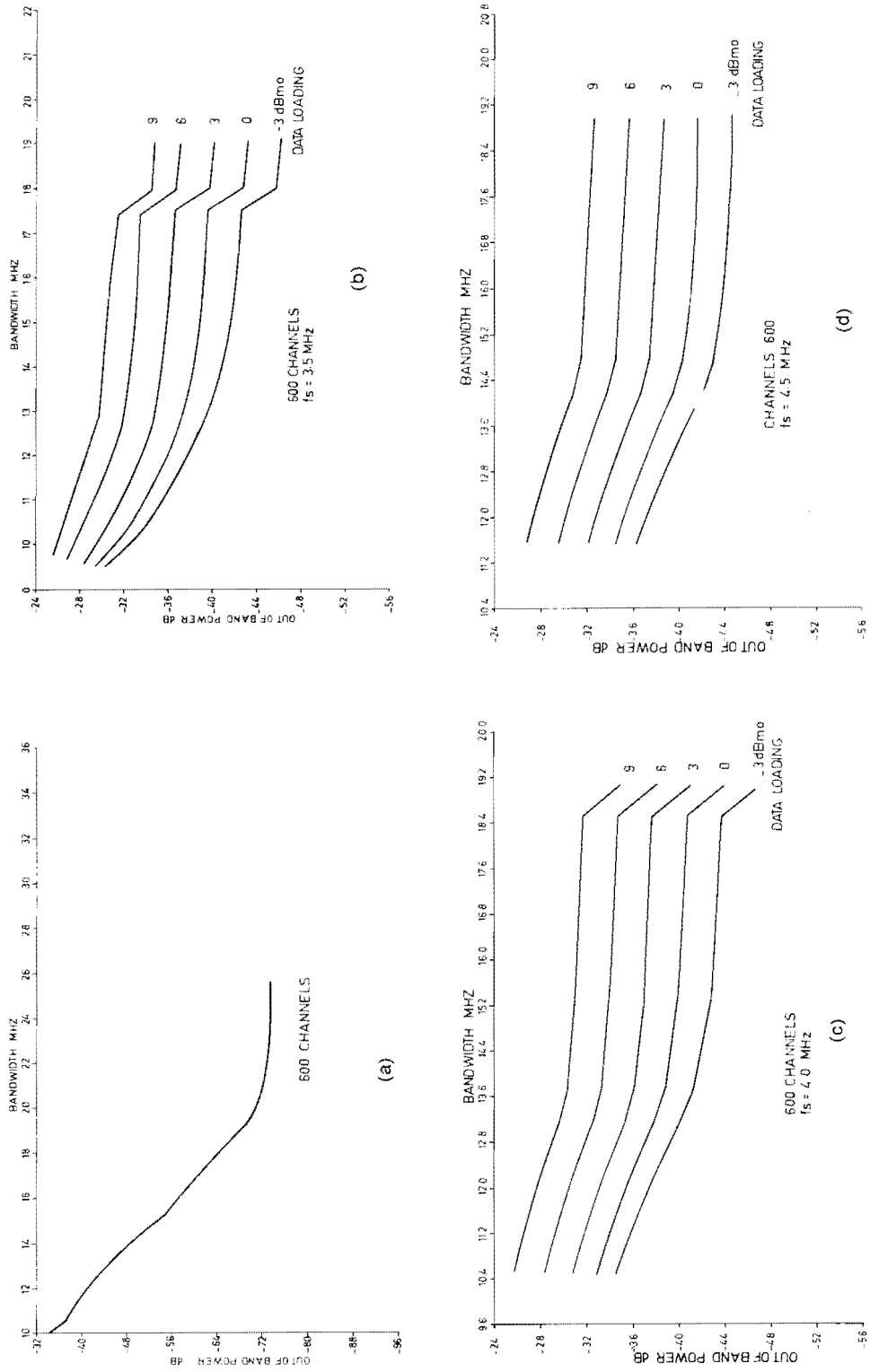

Fig. 2. Out-of-band power vs. bandwidth for 600 FDM channels: (a) FDM only; (b) data at 3.5 MHz; (c) data at 4 MHz; (d) data at 4.5 MHz.

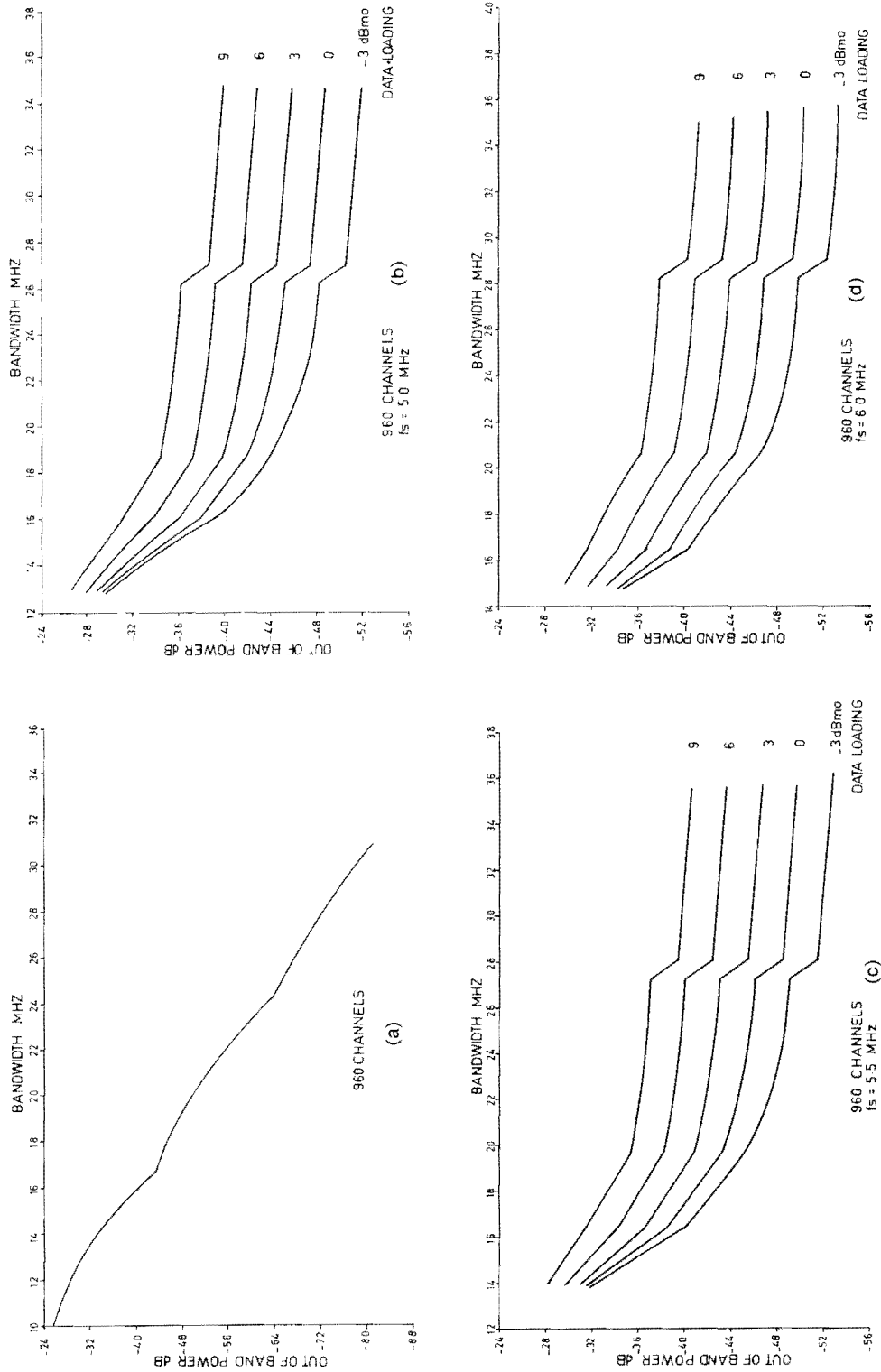

Fig. 3. Out-of-band power vs. bandwidth for 960 FDM channels; (a) FDM only; (b) data at 5 MHz; (c) data at 5.5 MHz; (d) data at 6 MHz.

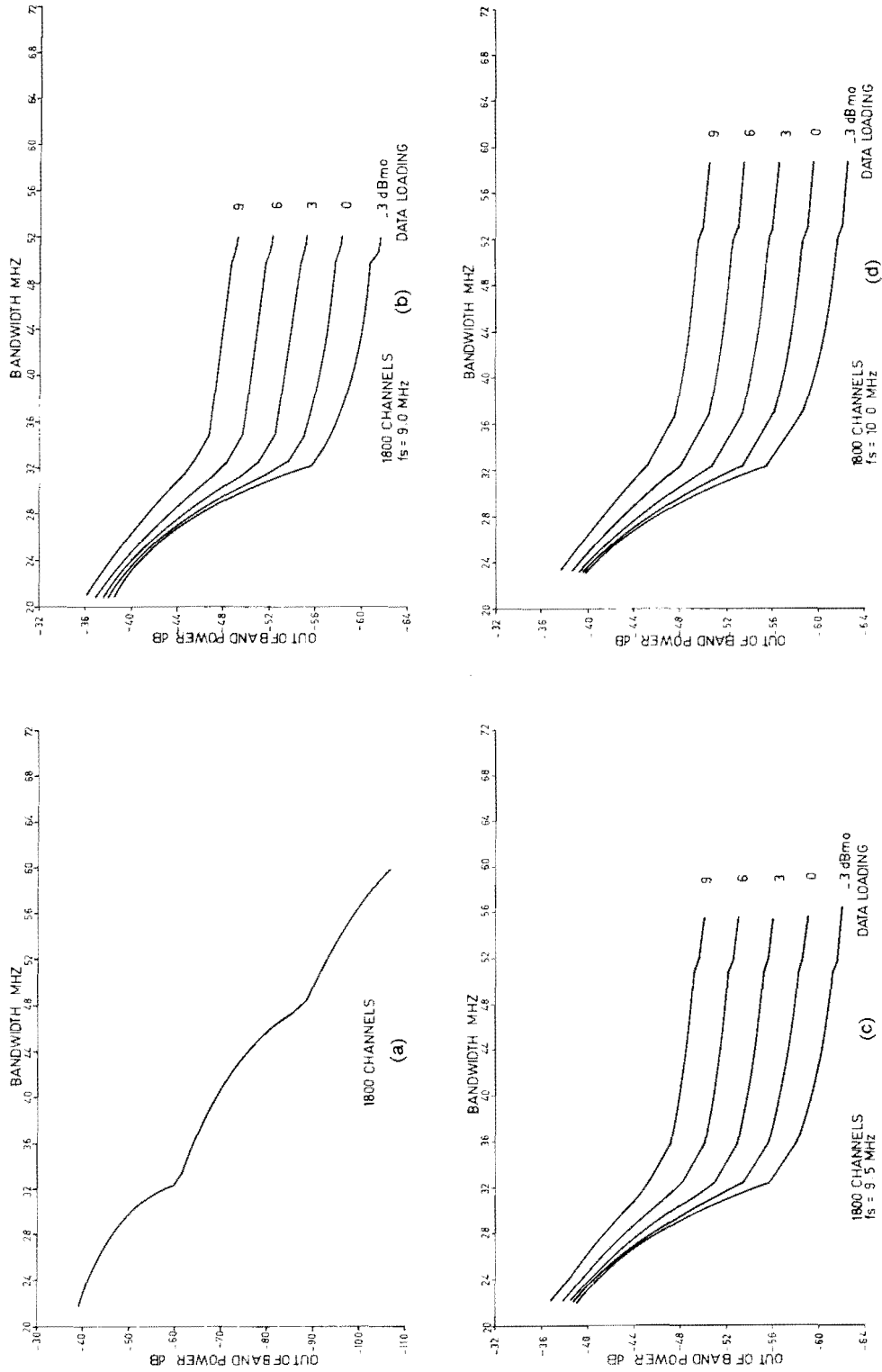

Fig. 4. Out-of-band power vs. bandwidth for 1800 FDM channels; (a) FDM only; (b) data at 9 MHz; (c) data at 9.5 MHz; (d) data at 10 MHz.

3.2. Out-of-band power for FDM-FM spectrum

The total power contained in a band extending over F to $-F$ around a sinusoidal carrier frequency modulated by the FDM signal is defined as

$$\bar{W}_{\text{FDM}}(F) = \int_{-F}^F W_{\text{FDM}}(f) df. \quad (42)$$

By substituting for $W_{\text{FDM}}(f)$ from eq. (31) and then integrating we get

$$\begin{aligned} \bar{W}_{\text{FDM}}(F) &= e^{-P} \sum_{n=0}^{\infty} \frac{(P)^n}{n!} \\ &\times \frac{1}{2^n} \sum_{0 \leq r < (r+n)/2} \frac{(-1)^2 (F+n-2r)^n - A(r)}{r!(n-r)!} \end{aligned} \quad (43)$$

where

$$A(r) = \begin{cases} (n-2r)^n, & 0 < r < \frac{1}{2}n, \\ 0, & r \geq \frac{1}{2}n. \end{cases}$$

3.3. Total spectrum

Applying the same definitions of the total in-band power given in eqs. (38) and (42), we get for the total signal spectrum, (using eq. (36),

$$\begin{aligned} \bar{W}_t(F) &= e^{-P} \bar{W}_{\text{PSK}}(F) + e^{-Q} \bar{W}_{\text{FDM}}(F) \\ &+ \sum_{m=1}^{\infty} \frac{q^m}{2^{2m} m!} \left\{ \sum_{r=0}^m \binom{2m}{r} \right. \\ &\times \left[\bar{W}'_{\text{FDM}}(F - (m-r)f_d) \right. \\ &+ \bar{W}'_{\text{FDM}}(F + (m-r)f_d) \\ &\left. \left. + \binom{2m}{m} \bar{W}'_{\text{FDM}}(F) \right] \right\} \end{aligned} \quad (44)$$

$\bar{W}_{\text{PSK}}(F)$ and $\bar{W}_{\text{FDM}}(F)$ are given by eqs. (41) and (43) respectively, and are used, together with eq. (44), to obtain the out-of-band power as a function of bandwidth for different PSK and FDM loading conditions. In Figs. 2, 3 and 4 we consider the simultaneous transmission of 600, 960, 1800

FDM voice channels; together with Data Above Voice signal. The DAV signal has a rate of 1.544 Mb/s, which is the standard T1 bit stream of 24 PCM voice channels. The data power for many working systems carrying DAV is typically 3 dB above test tone level. For 600 and 960 channels, an rms test tone deviation of 200 KHz is used, while 1800 channel radios have a test tone rms deviation of 140 KHz. In Fig. 2, for 600 voice channels, four cases are considered, namely, FDM only in Fig. 2(a) and in Figs. 2(b)–2(d) results for 3 different data subcarrier frequencies. For each frequency, five different data powers are considered. The data loading is related to the test tone deviation by

$$10 \log \left(\frac{\Delta F}{\Delta F_0} \right) = -3, 0, 3, 6, 9 \text{ dB} \quad (45)$$

where F_0 is the mean square test tone deviation and ΔF is the subcarrier mean square deviation. Figures 3 and 4 are similar to Fig. 2 but 960 and 1200 voice channels are considered respectively.

3.4. Necessary bandwidth

To calculate the necessary bandwidth for quality transmission of FM signals, Carson's rule has been used as a rule of thumb, providing satisfactory estimate of bandwidth in the case of FDM signals. The rule states that the necessary bandwidth B_N is

$$B_N = 2(F_m + D_m) \quad (46)$$

where F_m and D_m are the highest modulating frequency and peak frequency deviation, respectively. In the case of FDM only, the peak deviation D_m is a well defined parameter. However, such is not the case for hybrid modulation comprised of FDM and PSK, and Carson's rule fails to yield satisfactory results. For instance, the necessary bandwidth calculated from (46) for 960 FDM channels and PSK data with a subcarrier frequency of $f_d = 5$ MHz is 21.5 MHz, for data loading of $-3, 0, 3$ dB above the test tone level. The reason why the rule is 'insensitive' to variation in data loading power is because a much higher deviation signal (FDM) masks the effect of varying data power. On the other hand, for an out of band power of -44 dB with respect to the unmod-

ulated carrier, the necessary bandwidth can be read from Fig. 3(b) as 19, 22.5 and 27 MHz for the $-3, 0, 3$ dB respectively.

From the above discussion, it is seen that the use of Carson's rule in this case will result in a waste of spectrum for low deviation and adjacent channel interference for higher deviation. Such is actually the case whenever the rule is used to calculate bandwidth for a mixture of low deviation and high deviation signals transmitted simultaneously by FM.

A glance over the curves in Figs. 2 through 4 shows a discontinuity in the total power due to the first side-band $W_{\text{FDM}}(f \pm f_d)$. The curve for various data powers are parallel and tends to level off beyond a certain frequency. For 600 channels (high modulation index), the saturation shape is reached after two discontinuities, indicating that first and second side-bands of the data subcarrier have to be transmitted. For 1800 channels, only the first side-band needs to be included. We assumed in the above discussion that the out-of-band power is 45 dB below the unmodulated carrier. For -45 dB out-of-band power or 'band-limiting distortion' our results for FDM only agree with previously published results [9], see Table 1.

4. Conclusions

A closed form expression of the power spectrum for a sinusoidal carrier frequency modulated by PSK data subcarrier has been presented. Assuming ideal emphasis characteristics, a closed form expression for the FDM spectrum is also

derived. Then, utilizing the expressions of the individual spectra, the power spectrum of simultaneous FDM and PSK data above voice is obtained.

The above results are used to calculate the out-of-band power as a function of bandwidth for different voice and data parameters. The result is a set of design curves covering most practical design situations from which we conclude that:

(1) For FDM only, Carson's rule bandwidth corresponds to an out-of-band power of about -45 dB, in close agreement with published results [9].

(2) For PSK only, the bandwidth is independent of the subcarrier location. If all the first side-band is transmitted, i.e. $B_N \geq 2(f_d + F_m)$; the signal to distortion increases by 3 dB when the modulation index q is reduced by 2.

(3) For simultaneous FDM and PSK the necessary bandwidth is given by $2(f_d + kF_m)$ with the parameter $k = 1$ for low modulation index p (as in 1800 channels), $k = 2$ for high modulation index (600 channels), and $1 < k < 2$ for intermediate p (960, 1200 channels).

(4) The given spectrum formulas are valid for the transmission of FDM and PSK over terrestrial microwave, satellite, and cable systems.

References

- [1] K. Feher, R. Goulet and S. Morissette, 1.544 Mbit/s Data Above FDM Voice and Data Under FDM Voice Microwave Transmission, *IEEE Transactions on Communications*, Vol. 23 (1975) 1321-1326.

Table 1
Necessary bandwidth

FDM channels	p (rad) ²	F_m (MHz)	D (MHz)	Necessary bandwidth FDM only		f_d (MHz)	FDM + PSK ($q = 0.003$) Signal/distortion(dB)		
				B_N (MHz) ^a	B_N (MHz) ^b		$k = 1$ ^c	$k = 1.5$	$k = 2$
600	0.314	2.66	3.893	13.1	13	3.5	38	41.5	45
960	0.192	4.188	4.926	18.228	17.75	5	42	44.5	47
1800	0.0478	8.204	4.72	25.85	27	9	46	48.5	50

^a $B_N = 2(F_m + D)$.

^b B_N = Bandwidth for -45 dB distortion.

^c $B_N = 2(f_d + kF_m)$.

- [2] K. Feher and M. Morris, Simultaneous Transmission of Digital Phase-Shift Keying and of Analog Television Signals, *IEEE Transactions on Communications*, Vol. 23 (1975) 1509–1514.
- [3] K. Watanabe et al., PCM-FDM System for Existing Microwave Radio Base Band, *IEEE Transactions on Communications*, Vol. 24 (1976) 1346–1350.
- [4] K. Feher and M. Morris, Development in Canadian and International Data Above Voice/Video, *Proc. Canadian Communications & Power Conference* (1978) 79–80.
- [5] G. Vannucchi, Coexistence of Analog and Digital Signal on the Same Carrier, *Alta Frequency*, Vol. XLI, No. 8 (1972) 215E–255E.
- [6] D. Kirk, Jr. and M.J. Paolini, PCM Subchannels for Video Microwave, *IEEE Transactions on Broadcasting*, Vol. 18, No. 2 (1972) 39–44.
- [7] K. Feher, R. Goulet and S. Morissette, Performance Evaluation of Hybrid Microwave Systems, *IEEE Transactions on Communications*, Vol. 22 (1974) 873–877.
- [8] L. Lundquist, Channel Spacing and Necessary Bandwidth in FDM-FM Systems, *The Bell System Technical Journal*, Vol. 50, No. 3 (1971) 869–880.
- [9] S.C. Plotkin, FM Bandwidth as a Function of Distortion and Modulation Index, *IEEE Transactions on Communication*, Vol. 15 (1967) 467–470.
- [10] M. Mueller and T.L. Gentry, Spectral Energy Distribution of Radio Link FM, *IEEE Transactions on Communications*, Vol. 20 (1972) 165–173.
- [11] A. Anuff, A Note on Necessary Bandwidth in FM Systems, *Proceedings of the IEEE*, Vol. 59 (1971) 1522–1523.
- [12] C. Craig Ferris, Spectral Characteristics of FDM-FM Signals, *IEEE Transactions on Communications*, Vol. 16, No. 2 (1968) 233–237.
- [13] H.E. Rowe and V.S. Prabhu, Spectra of Low-Deviation Frequency-Modulated Waves, *IEEE Transactions Communications*, Vol. 19, No. 6 (1971) 1172–1178.
- [14] D. Middleton, *An Introduction to Statistical Communication Theory* (McGraw-Hill, New York, 1960).
- [15] P.B. Joyns and T.R. Rowbotham, *Communication Systems Analysis* (Butterworth, London, 1972).
- [16] W.S. Sullivan, High Capacity Microwave System for Digital Data Transmission, *IEEE Transactions on Communications*, Vol. 20 (1972) 466–470.
- [17] E.H. Rowe, *Signals and Noise in Communication System* (Van Nostrand, New York, 1965).
- [18] R.G. Medhurst, RF Spectra of Waves Frequency Modulated with White Noise, *Proceedings of the IEE (London)*, Vol. 107 (1960) 314–327.
- [19] N. Blachman, Limiting Frequency Modulation Spectra, *Information and Control*, Vol. 1 (1957) 26–37.
- [20] N.M. Blachman and G.A. McAlpine, The Spectrum of a High Index FM Waveform: Woodward's Theorem Revisited, *IEEE Transactions on Communications*, Vol. 17 (1969) 201–208.
- [21] D. Slepian, An Expansion for FM Spectra, *IEEE Transactions on Communications*, Vol. 19 (1971) 223–225.
- [22] N. Abramson, Bandwidth and Spectra of Phase-and-Frequency Modulated Waves, *IEEE Transactions on Circuits and Systems*, Vol. 11 (1963) 407–414.
- [23] V.K. Prabhu and H.E. Rowe, Spectral Density Bounds of a PM Wave, *The Bell System Technical Journal*, Vol. 48 (1969) 769–811.
- [24] R.G. Medhurst and J.H. Roberts, Evaluation of Distortion in F.M. Trunk Radio Systems by a Monte-Carlo Method, *Proceedings of the IEE (London)*, Vol. 113 (1966) 570–580.
- [25] S.V. Borodich, The Required Bandwidth of FM Multi-Channel Transmission Systems, *Telecommunications and Radio Engineering*, Part 1, Vol. 32 (1978) 1–7.
- [26] A. Erdelyi, Ed., *Tables of Integral Transforms* (McGraw-Hill, New York, 1954) 20.